

Art Code: 4440

Art Code	Ømm	Grams/Pcs
4440-1	1	15
4440-2	2	20
4440-3	3	35
4440-4	4	40
4440-5	5	55
4440-6	6	55
4440-7	7	75
4440-8	8	75
4440-9	9	80
4440-10	10	105
4440-11	11	105
4440-12	12	115
4440-13	13	140
4440-14	14	140
4440-15	15	140
4440-16	16	140
4440-17	17	185
4440-18	18	185
4440-19	19	185
4440-20	20	245
4440-22	22	260
4440-23	23	350
4440-26	26	335
4440-28	28	400
4440-36	36	580
4440-38	38	580
4440-40	40	630

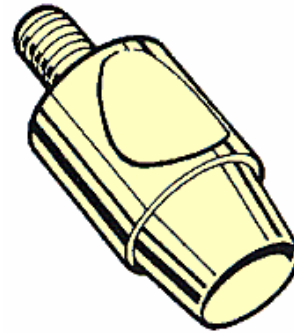

Art Code: 4444

Suitable for Machine 4430&4431. Section 5 Page 3.
Passande till maskin 4430&4431. Sektion 5 sidan 3.
Passend für machinen 4430& 4431. Abschnitt 5 seite.3.
Convenable pour Machine 4430 & 4431. Voir Sect 5 page 3.

Art Code	Ømm	Grams/Pcs
4444-1.0	1.0	10
4444-1.5	1.5	10
4444-2.0	2.0	12
4444-2.5	2.5	12
4444-3.0	3.0	12
4444-3.5	3.5	12
4444-4.0	4.0	13
4444-4.5	4.5	13
4444-5.0	5.0	12
4444-5.5	5.5	12
4444-6.0	6.0	10
4444-6.5	6.5	10
4444-7.0	7.0	10
4444-8.0	8.0	25
4444-9.0	9.0	25
4444-10.0	10.0	25
4444-11.0	11.0	25
4444-12.0	12.0	25

Art Code	Mtrl Code	A MM	B MM	Grams/Pcs
4444	M00	12.5	16.0	20

Brass Die

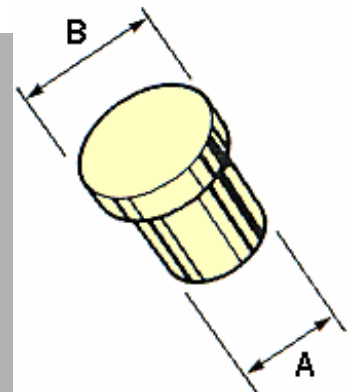

Art Code	A MM	B MM	C MM	Grams/ Pcs
33-6 K	8	70	38	850
33-8 K	10	70	38	850

Die

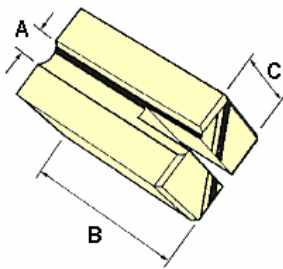

Punch

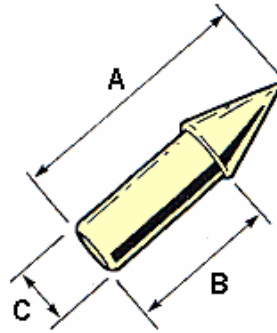
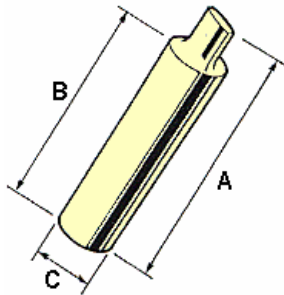

Arrow Head

Art Code	A MM	B MM	C MM	Grams/ Pcs
33 S	50	28	10.5	10

Art Code	A MM	B MM	C MM	Grams/ Pcs

Art Code	A MM	B MM	C MM	Grams/ Pcs
33 R	70	60	16	90

Art Code	A MM	B MM	C MM	Grams/ Pcs
33-6 H	80	13	3.0	75
33-8 H	80	13	3.0	75

Arrow Holder

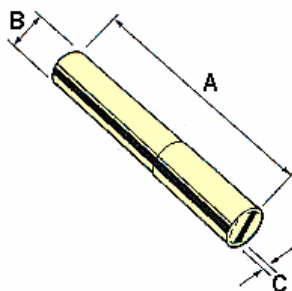

Art Code	A MM	B MM	C MM	Grams/ Pcs

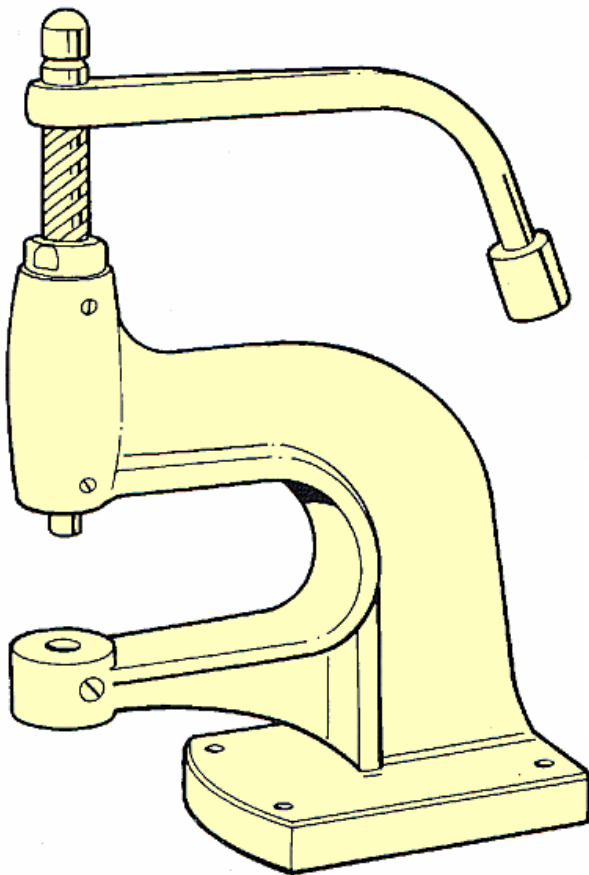

Art Code: 4430

Net Weight..... Approx. 4 Kgs
 Total Height31 cms
 Throat 110 mm
 Total Clearance 55 mm
 Clearance up to Pressure Bolt 44 mm
 On Special Request:
 Clearance up to 52 mm
 Stroke – approx 30 mm

Art Code: 4431

Net Weight..... Approx. 6.5 Kgs
 Total Height 45 cms
 Throat 120 mm
 Total Clearance 75 mm
 Clearance up to Pressure Bolt 45 mm
 On Special Request:
 Clearance up to 70 mm
 Stroke – approx 30 mm

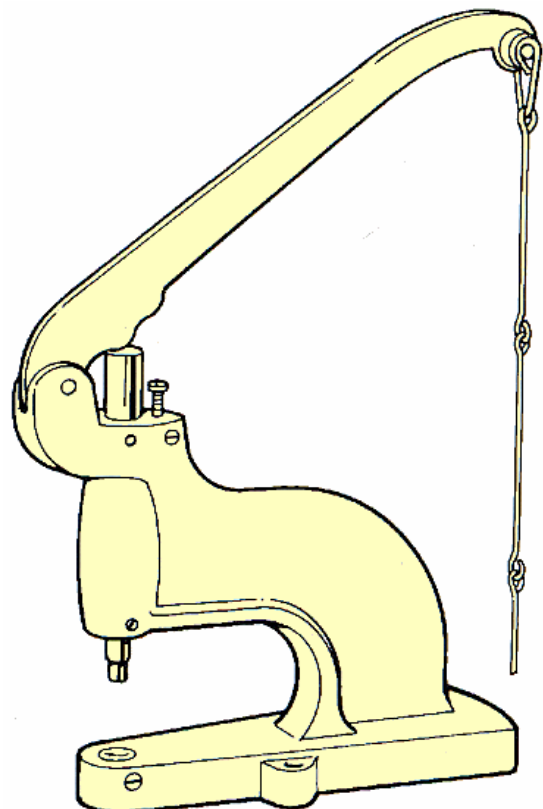

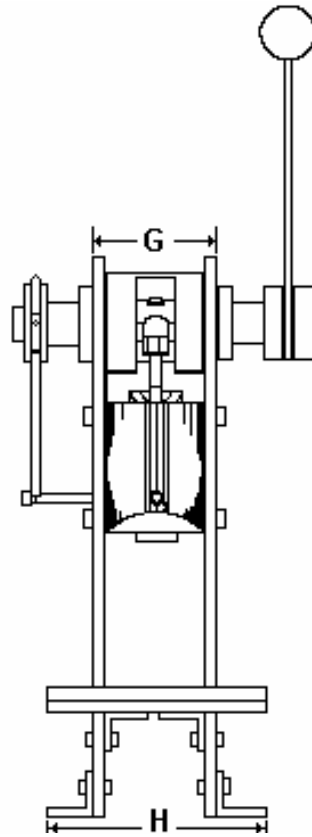
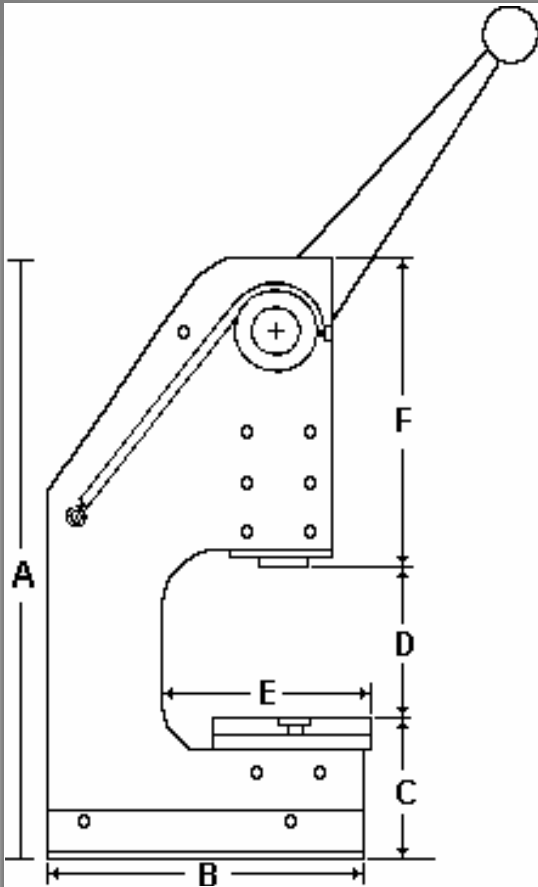

Bench Press

Art Code	A MM	B MM	C MM	D MM	E MM	F MM	G MM	H MM	Pressure Approx.	Piston-stroke	Net Weight
4432	445	260	80	130	160	235	90	170	1500 kg	45 mm	25 kg

Art Code	Throat Depth	Can close eyelets up to	Pressure Approx.	Piston-stroke	Net Weight
AP1	102	62,5	1000 kg	120	30 kg

Bench Mounted Hand Press



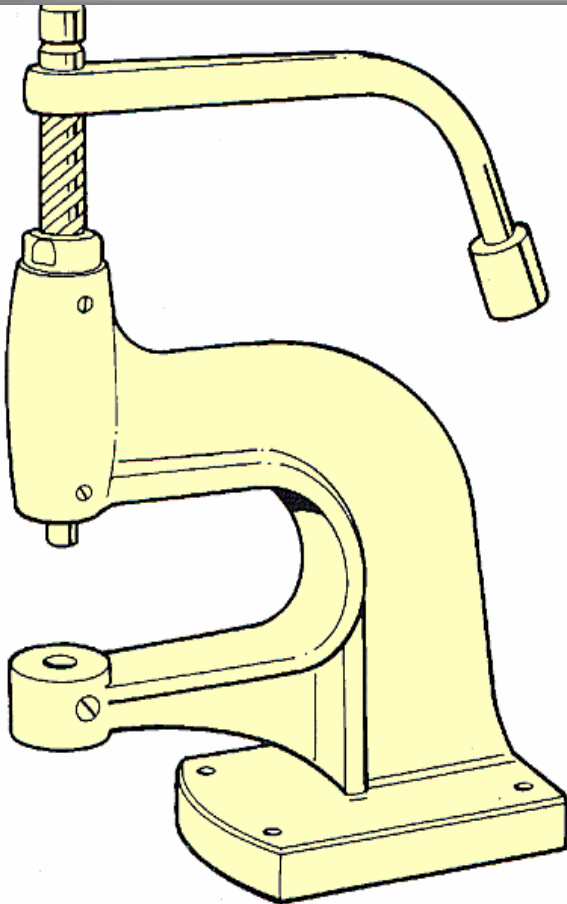

Art Code: 4430-1

Net Weight..... Approx. 2.8 Kgs
 Total Height26 cms
 Throat 86 mm
 Total Clearance 0 mm
 Clearance up to Pressure Bolt 46 mm
 On Special Request:
 Clearance up to 46.8 mm
 Stroke – approx 30 mm

Art Code: 4431-2

Net Weight..... Approx. 5.5 Kgs
 Total Height 30 cms
 Throat 130 mm
 Total Clearance 0 mm
 Clearance up to Pressure Bolt 46.4 mm
 On Special Request:
 Clearance up to 42 mm
 Stroke – approx 34 mm

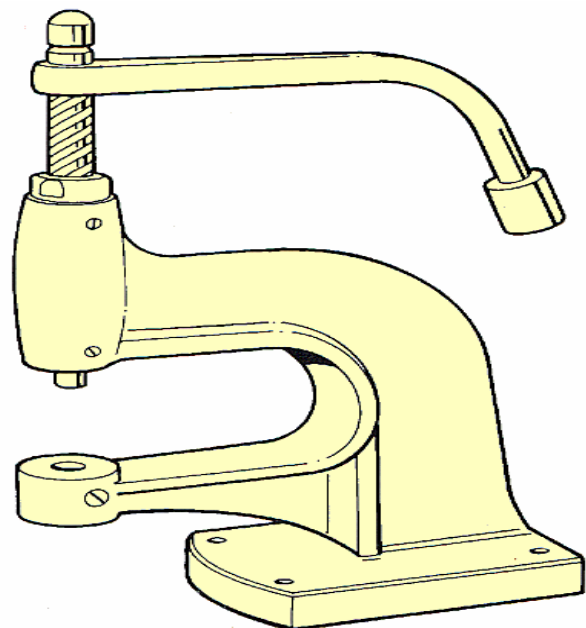

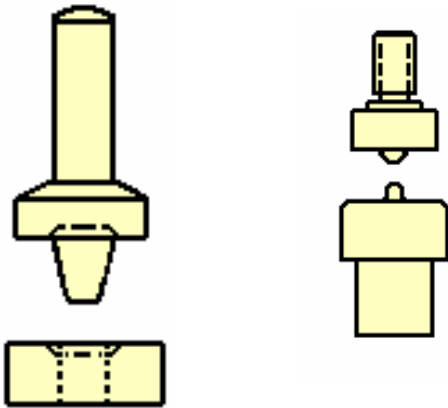

Art Code	Description	Hand Tools Punch & Dies		Hand Tools Punch & Dies		Designated Hollow Punch Art Code	Suitable Hollow Punch	
		Art Code	Pcs/Set	Art Code	Pcs/Set		4440	4444
20 B	Sail Eyelets	20 B HV	2	20 B MV	2		7 mm	7 mm
21 B	Sail Eyelets	21 B HV	2	21 B MV	2		7 mm	7 mm
22 B	Sail Eyelets	22 B HV	2	22 B MV	2		8 mm	8 mm
23 B	Sail Eyelets	23 B HV	2	23 B MV	2		9 mm	9 mm
24 B	Sail Eyelets	24 B HV	2	24 B MV	2		9 mm	9 mm
25 B	Sail Eyelets	25 B HV	2	25 B MV	2		10 mm	10 mm
26 B	Sail Eyelets	26 B HV	2	26 B MV	2		11 mm	11 mm
27 B	Sail Eyelets	27 B HV	2	27 B MV	2		12 mm	12 mm
28 B	Sail Eyelets	28 B HV	2	28 B MV	2		13 mm	13 mm
29 B	Sail Eyelets	29 B HV	2				13 mm	
30 B	Sail Eyelets	30 B HV	2				16 mm	
31 B	Sail Eyelets	31 B HV	2				17 mm	
32 B	Sail Eyelets	32 B HV	2				19 mm	
33 B	Sail Eyelets	33 B HV	2				22 mm	
35 B	Sail Eyelets	35 B HV	2				26 mm	
000 Gr	Grommets	OOOGR HV	2				5 mm	5 mm
00 Gr	Grommets	OO GR HV	2				7 mm	7 mm
0 Gr	Grommets	O GR HV	2				8 mm	8 mm
1 Gr	Grommets	1 GR HV	2				11 mm	11 mm
2 Gr	Grommets	2 GR HV	2				10 mm	10 mm
3 Gr	Grommets	3 GR HV	2				14 mm	
4 Gr	Grommets	4 GR HV	2				15 mm	
5 Gr	Grommets	5 GR HV	2				16 mm	
6 Gr	Grommets	6 GR HV	2				19 mm	
7 Gr	Grommets	7 GR HV	2				23 mm	
8 Gr	Grommets	8 GR HV	2				28 mm	

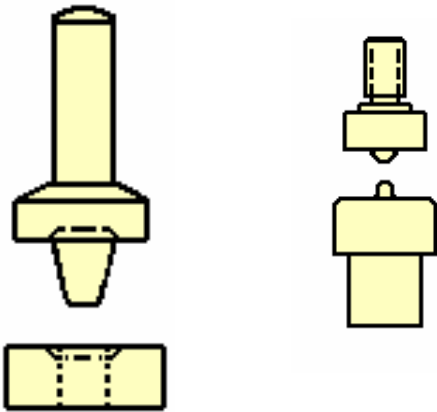

Art Code	Description	Hand Tools Punch & Dies		Machine Tools for Art No 4430 & 4431		Designated Hollow Punch Art Code	Suitable Hollow Punch	
		Art Code	Pcs/Set	Art Code	Pcs/Set		Art Code 4440	Art Code 4444
00 SH	Sheet Eyelets	00 SH HV	2				5 mm	5 mm
0 SH	Sheet Eyelets	0 SH HV	2				6 mm	6 mm
1 SH	Sheet Eyelets	1 SH HV	2				8 mm	8 mm
2 SH	Sheet Eyelets	2 SH HV	2				9 mm	9 mm
3 SH	Sheet Eyelets	3 SH HV	2				11 mm	11 mm
3.5 SH	Sheet Eyelets	3.5 SH HV	2				11 mm	11 mm
4 SH	Sheet Eyelets	4 SH HV	2				13 mm	
5 SH	Sheet Eyelets	5 SH HV	2				16 mm	
6 SH	Sheet Eyelets	6 SH HV	2				20 mm	
5	Shoe Eyelets			5 MV	2		5 mm	5 mm
7	Shoe Eyelets			7 MV	2		4 mm	4 mm
8	Shoe Eyelets			8 MV	2		5 mm	5 mm
9	Shoe Eyelets			9 MV	2		5 mm	5 mm
10	Shoe Eyelets			10 MV	2		6 mm	6 mm
1800-65	Rect. Eyelets	1800-65 HV	2			1800-65 HP		
15	Round Eyelets	15 HV	2	15 MV	2	64 HP	16 mm	
38	Round Eyelets	38 HV	2			67 HP	19 mm	
30 R	Round Eyelets	30 R HV	2				28 mm	
40 R	Round Eyelets	40 R HV	2				40 mm	
40-10	Oval Eyelets	40-10 HV	2			40-10 HP		
40-20	Round Eyelets	40-20 HV	2			40-20 HP		
64	Rect. Eyelets	30 R HV	2			64 HP		
67	Rect. Eyelets	40 R HV	2			67 HP		

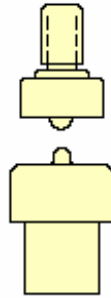
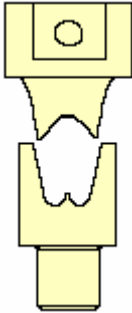

Art Code	Description	Hand Tools Punch & Die		Machine Tools for Art 4430 & 4431		Designated Hollow Punch Art Code	Suitable Hollow Punch	
		Art Code	Pcs/Set	Art Code	Pcs/Set		Art Code 4440	Art Code 4444
10100-1,5	Clips 1,5mm			10100-1,5 MV	2			
10100-2,5	Clips 2,5mm			10100-2,5 MV	2			
10100-5	Clips 5mm			10100-5 MV	2			
10100-8	Clips 8mm			10100-8 MV	2			
1602	Glove Eyelet			1602 MV	2		8 mm	8 mm
1603	Ball Tip			1603 MV	2			
503-4	Rivet Cap			505-4 MV	2		2 mm	2 mm
504-7	Rivet Cap			505-7 MV	2		3 mm	3 mm
504-8	Rivet Cap			505-7 MV	2		4 mm	4 mm
504-10	Rivet Cap			505-10 MV	2		4 mm	3,5 mm
508-13	Rivet Cap			505-13 MV	2		5 mm	5 mm
545-8	Rivet Cap			545-8 MV	2		3 mm	3 mm
840	Press fastener "S"			840 MV	4			
844	Press fastener "S"			844 MV	4			
846	Press fastener "S"			846 MV	4			
848	Press fastener			848 MV	4			
850	Press fastener	850 HV	2	850 MV	4		4 mm	4 mm
897	Eyelet w Prongs					897 HP		
898	Oval Eyelet	898 HV	2	898 MV	2	898 HP	11 mm	11 mm
900	Pull It Up					900 HP		
901	Stud Cloth/Cloth	901 HV	2	901 MV	2		5 mm	5 mm

Consumer Tools

Art Code	1 off	1 off	Grams/ pcs	Pcs/ Box
505-7 HV M	505-7 HV M D	505-7 HV M P	25	1
505-10 HV M	505-10 HV M D	505-10 HV M P	45	1

Converting Tools

Art Code	1 off	1 off	Grams/ pcs	Pcs/ Box
505 MV-HV	505 MV-HV P	505 MV-HV D	500	1

Dead-Blow Mallet

Art Code	A MM	B MM	C MM	Grams/ pcs
KG-35	310	112	270	650
KG-50	320	120	265	1080
KG-60	330	145	270	1700

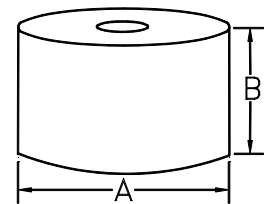
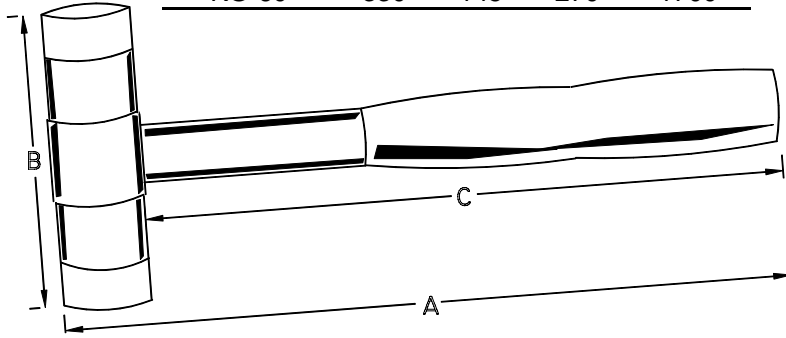

Cutting-block

Art Code	A MM	B MM	C MM	D MM	Kgs/ 1000
KG-U	300	200	25		1400

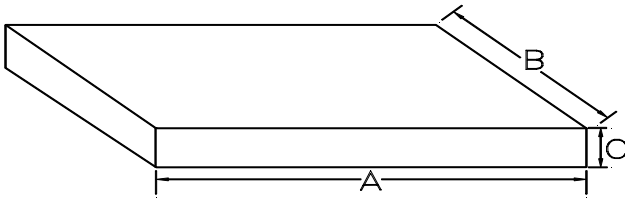

Nylon Ends

Art Code	A MM	B MM	C MM	D MM	Grams/ pcs
KG-35 S	35	22			20
KG-50 S	50	26			55
KG-60 S	60	32			95

Art Code	A MM	B MM	C MM	D MM	Kgs/ pcs

Art Code	A MM	B MM	C MM	D MM	Kgs/ 1000
KG-UG	200	200	25		900

Cutting-block

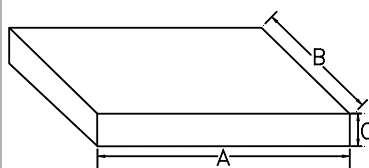

Art Code	A MM	B MM	C MM	D MM	Kgs/ pcs